

Quadro Set with Sandpit

12494EPZN

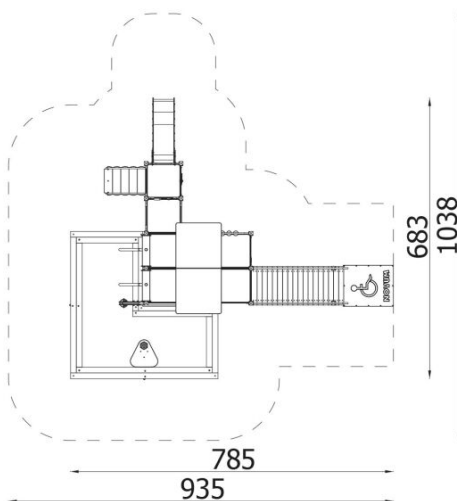
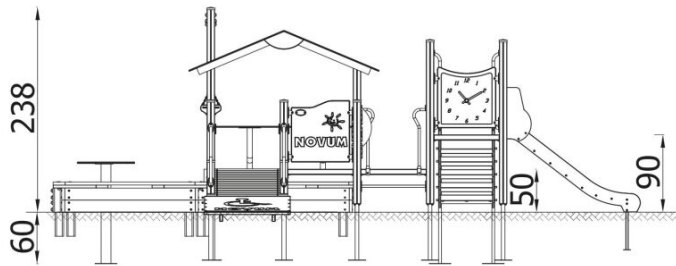

DESCRIPTION

8 square platforms, roof for two platforms, stainless steel slide, HDPE stairs, entry ramp, climbing wall (integration set), 5 security panels (including tic-tac-toe and clock), shop panel, sand winch, sandbox table, sandbox 3,58x3,58, shelf with tube for pouring sand

INFORMATION

Number of users	25
Age range	0 - 6
Device dimensions [m]	6.83 x 2.38 x 7.85
Compliance with the norm	EN 1176
Spare parts	

SAFETY SURFACE

Zone	Max height of fall [m]	Area [m ²]	Perimeter of safety zone [m]
A	1	67.5	34.5
B			
C			